

## 1. Description

TM1809 is a 9-channel LED driver control IC. Internal integrated with MCU digital interface, data flip-latch, LED high voltage driver and so on. Through the external MCU control, the chip can achieve separate luminance, and through cascade control can achieve outdoor large-screen color dot-matrix light-emitting control. TM1809 have excellent performance and high reliability.

## 2. Feature

- Use high-voltage power CMOS process
- Output pin tolerance voltage is up to 24V
- Input voltage can support 6 ~24V via outside resistance connected to chip VDD pin
- Build-in stabilized voltage supply circuit
- Brightness adjustment circuit(256 level)
- Signal line for series cascade interface
- Oscillation mode: Built-in double RC oscillator and clock synchronization
- Built-in power-on reset circuit
- PWM control side can achieve 256 adjustment, scan frequency not less than 400hz / s
- When the refresh rate is 30 frames/ s, the number of cascade is not less than 540 on low-speed mode. And it is not less than 1080 on high-speed mode
- Data transmission speed have two selected mode ( 400Kbps and 800Kbps )
- SOP14

## 3. PIN Configuration

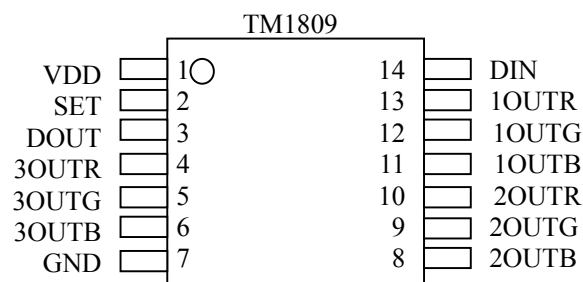

#### 4. PIN identifications

PIN NO.	Configuration	PIN name	Description
14	DIN	Data in	Display data in
3	DOUT	Data out	Display cascade data out
2	SET	Set mode	Connect to VDD: low-speed mode; Floating: high-speed mode
13	1OUTR	LED driver output	First red PWM control output
12	1OUTG	LED driver output	First green PWM control output
11	1OUTB	LED driver output	First blue PWM control output
10	2OUTR	LED driver output	Second red PWM control output
9	2OUTG	LED driver output	Second green PWM control output
8	2OUTB	LED driver output	Second blue PWM control output
4	3OUTR	LED driver output	Third red PWM control output
5	3OUTG	LED driver output	Third green PWM control output
6	3OUTB	LED driver output	Third blue PWM control output
1	VDD	Logical power supply	5V±10%
7	GND	Logical GND	Connect to system GND

#### 5. Electrical parameters

**Limited parameter (Ta = 25°C, Vss = 0 V)**

Parameter	Symbol	Range	Unit
Logic power supply voltage	VDD	+4.5 ~ +5.5	V
Output tolerance voltage	VOUTx	24	V
Logic input voltage	VII	-0.5 ~ VDD + 0.5	V
LED driver output current	IO1	80	mA
Power Dissipation	PD	400	mW
Operating Temperature	Topt	-40 ~ +80	°C
Storage Temperature	Tstg	-65 ~ +150	°C

**The normal scope of work (Ta = -20 ~ +70°C, Vss = 0 V)**

Parameter	Symbol	Min	Typical	Max.	Unit	Test Condition
Logic power supply voltage	VDD		5		V	-
High-level voltage	VIH	0.7 VDD	-	VDD	V	-
Low-level voltage	VIL	0	-	0.3 VDD	V	-

**Electrical characteristics (Ta = -20 ~ +70°C, VDD = 4.5 ~ 5.5 V, Vss = 0 V)**

Parameter	Symbol	Min	Typical	Max.	Unit	Test Condition
Low-level output current	IOL1	50	80	-	mA	OUTR/OUTG/OUTB Vo=0.3V
Low-level output current	Idout	10	-	-	mA	VO = 0.4V, DOUT
Input Current	II	-	-	±1	μA	VI = VDD / VSS
High-level input voltage	VIH	0.7 VDD	-		V	DIN, SET
Low-level input voltage	VIL	-	-	0.3 VDD	V	DIN, SET
Hysteresis voltage	VH	-	0.35	-	V	DIN, SET
Dynamic current consumption	IDDdyn	-	-	1	mA	No load, display off
Power Dissipation	PD			250	mW	(Ta=25°C)
Thermal Resistance	Rth(j-a)	79.2		190	°C/W	

**Switching characteristics (Ta = -20 ~ +70°C, VDD = 4.5 ~ 5.5 V)**

Parameter	Symbol	Min	Typical	Max.	Unit	Test Condition
Oscillation frequency	Fosc1	-	400	-	KHz	/
	Fosc2	-	800	-	KHz	/
Propagation delay time	tPLZ	-	-	300	ns	DIN → DOUT
	tPZL	-	-	100	ns	CL = 15pF, RL = 10K Ω

Fall Time	TTHZ	-	-	120	$\mu$ s	CL = 300pF, OUTR/OUTG/OUTB
Data rate	Fmax	400	-	-	Kbps	Duty rate 50%
Input capacitance	CI	-	-	15	pF	-

## 6. Function Description

TM1809 adopts single wire to communicate and RZ (return to zero code) method to sent signal. On power-on reset status, when chip receive complete three groups of 24bits data from DIN, it begin transmitting data to next chip via DO. Before transmission, DO will be keep low-level. OUTR, OUTG, OUTB these 3 PWM will output different duty signal according to received data, the cycle of signal is 4ms.If input signal is RESET, the chip will be ready to receive new data after displaying all the received data. The same when receive new 3 groups of 24bit data completely, it will transmit them to next chip via DO.

TM1809 has the ability of auto-shape and signal transmission. The number of cascade is not limited by signal transmission, just limited by screen refresh speed. For example, we design 1080 cascade with 360ea TM1809 IC, the refresh time can be calculated is  $360 \times 0.8 \times 2 = 0.576\text{ms}$  (delay time per IC is 0.8us), no any twinkle will be detected.

## 7. Timing Waveform

### Input Pattern

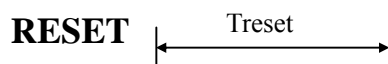
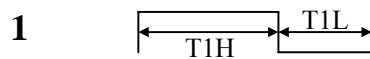
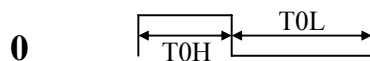

### Low-speed mode time

Name	Description	Min	TYP	Max	Unit
T0H	0, high-level time	450	600	750	ns
T1H	1, high-level time	1050	1200	1350	ns
T0L	0, low-level time	1050	1200	1350	ns
T1L	1, low-level time	450	600	750	ns
Treset	Reset, low-level time	-	24	>24	us

**High-speed mode time**

Name	Description	Min	TYP	Max	Unit
T0H	0, high-level time	250	320	390	ns
T1H	1, high-level time	530	600	670	ns
T0L	0, low-level time	530	600	670	ns
T1L	1, low-level time	250	320	390	ns
Treset	Reset, low-level time	-	24	>24	us

**Connection mode**

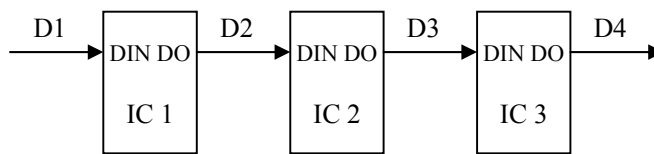

**Data transmission method:**

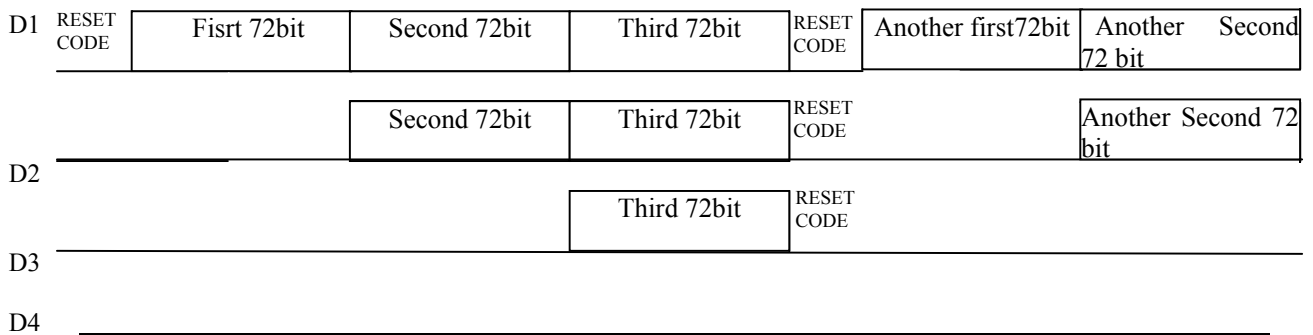

**72bit data structure**

1R7	1R6	1R5	1R4	1R3	1R2	1R1	1R0	1G7	1G6	1G5	1G4	1G3	1G2	1G1	1G0
1B7	1B6	1B5	1B4	1B3	1B2	1B1	1B0	2R7	2R6	2R5	2R4	2R3	2R2	2R1	2R0
2G7	2G6	2G5	2G4	2G3	2G2	2G1	2G0	2B7	2B6	2B5	2B4	2B3	2B2	2B1	2B0
3R7	3R6	3R5	3R4	3R3	3R2	3R1	3R0	3G7	3G6	3G5	3G4	3G3	3G2	3G1	3G0
3B7	3B6	3B5	3B4	3B3	3B2	3B1	3B0								

Upper bit first, sent data in accordance with R, G, B order.

8. Power Requirement and application circuit

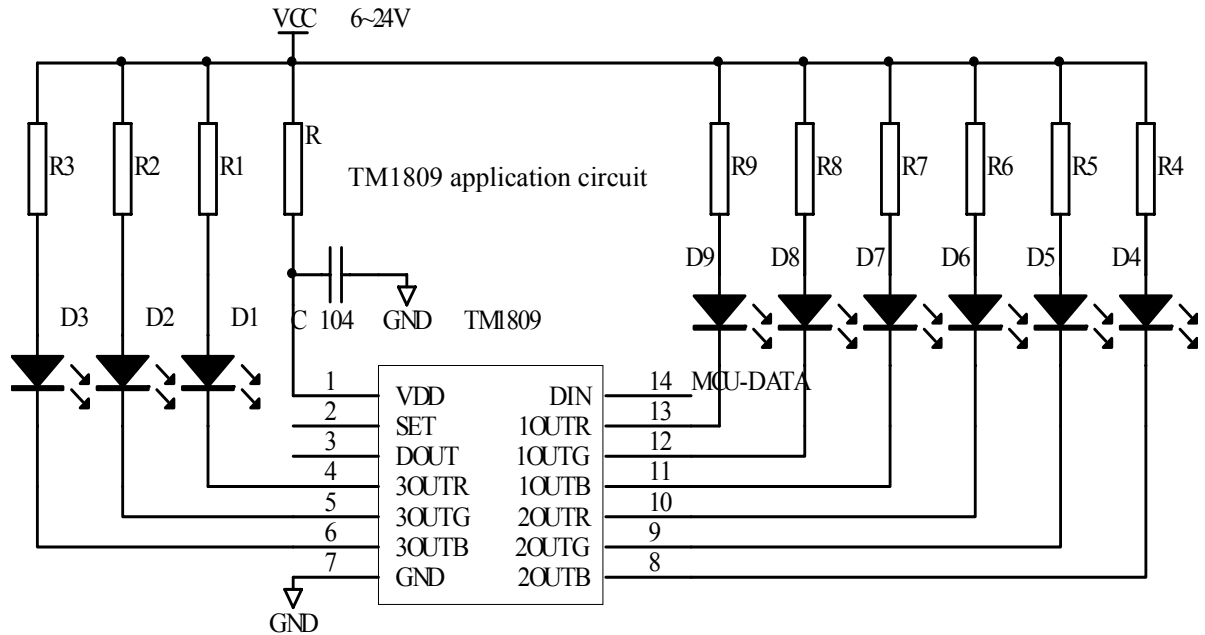

The capacitance 104 should near to IC power

According to different supply power voltage, different resistance is requested to add between power supply interface and VDD PIN of TM1809. The resistance as the below for application reference,

Supply power	Resistance
6V	1K
9V	4K
12V	7K
24V	20K

VDD voltage keeps invariable 5v in the actual application. SET should be connected with VDD not with outside power VCC to prevent IC breakdown.

9. IC Package diagram  
SOP14:

