



instructables

## Build a Colorful LED Tower Display Rhythm Lamp Light DIY Kits



by ICStation

ICStation Team makes this LED tower kits for DIY fun. And this LED Tower is imitated from Guangzhou Tower. We combined with the single-chip micro-chip display technology, we can make the beauty of the Guangzhou Tower. We use STC12C5A60S2 as a control system, the display part is 16\*16 dot matrix

display, through the production of the Guangzhou Tower, can better enhance the microcontroller on the principle of dot matrix display. Now let's start the steps!



## Step 1: Parameter and Feature for This Kit

### Parameter

- 1>.PCB size:78\*78mm
- 2>.Tower size:90\*78\*450mm(Different people installed, the height will be slightly different)
- 3>.Power:DC 5V
- 3>.Plug-in components used to make high success rate
- 4>.Give some code(The default code inside the chip,

### Feature

- 1>. 16\*16 led lattice design
- 2>.A variety of modes can be freely converted: ---- Offline animation mode(More than a dozen) ----Music spectrum mode(Flash with music)
- the function is more abundant,So please do not update the code inside arbitrarily)
- 5>.USB power audio line

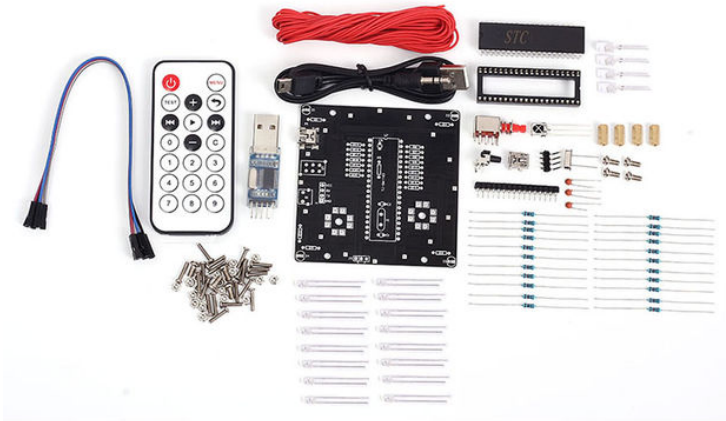

## Step 2: Schematic for Your Referance

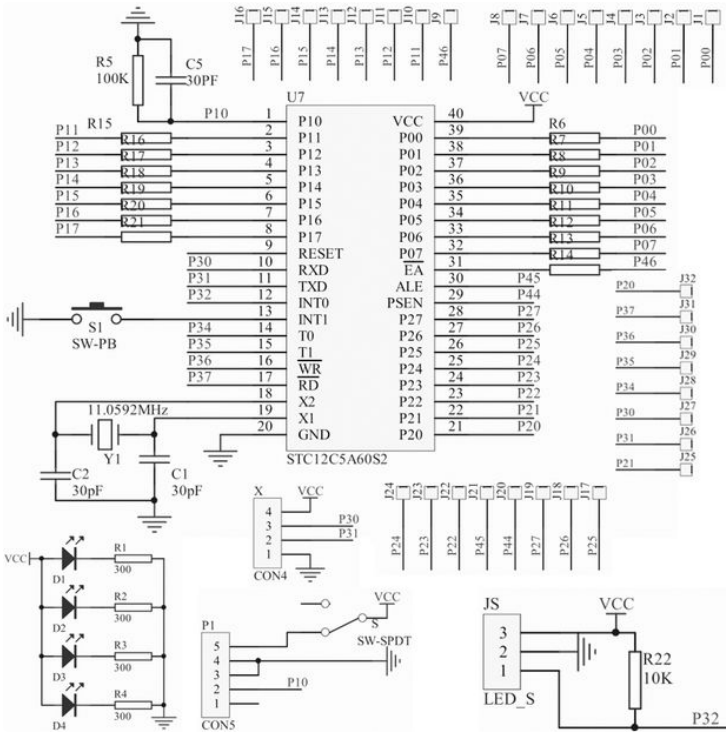

### Step 3: Check the Component Listing and Description Before the Installation

- |                                     |                                   |
|-------------------------------------|-----------------------------------|
| 1>.1pcs STC12C5A60S2 DIP-40         | 13>.1pcs Button                   |
| 2>.1pcs IC Socket DIP-40            | 14>.1pcs 4P Male Pin              |
| 3>.20pcs 300ohm Metal film resistor | 15>.271pcs Colorful 3mm LED       |
| 4>.1pcs 100K Metal film resistor    | 16>.1pcs USB/Audio Cable          |
| 5>.1pcs 10K Metal film resistor     | 17>.4pcs M3*10 Copper pillars     |
| 6>.3pcs 30P Ceramic capacitors      | 18>.4pcs M3*6 Screw               |
| 7>.4pcs Colorful 5mm LED            | 19>.1pcs USB-TTL Downloader       |
| 8>.1pcs 11.0592MHz Crystal          | 20>.5pcs 20mm DuPont line         |
| 9>.1pcs Mini USB Socket             | 21>.1pcs Remote control           |
| 10>.1pcs 16P Round Pin              | 24>.1pcs 4.2m Cable               |
| 11>.1pcs VS1838B Infrared sensor    | 25>.1pcs PCB                      |
| 12>.1pcs Self-locking switch        | 26>.1pcs Acrylic welding template |

NO.	Component Name	PCB Marker	Parameter	QTY	Remarks
1	STC12C5A60S2		DIP-40	1	
2	IC Socket	U7	DIP-40	1	
3	Metal film resistor	R1-R4,R6-R21	300ohm	20	
4	Metal film resistor	R5	100K	1	
5	Metal film resistor	R22	10K	1	
6	Ceramic capacitors	C1,C2,C5	30P	3	
7	5mm LED	D1-D4	Colorful	4	
8	Crystal	Y1	11.0592MHz	1	
9	Mini USB	P1		1	
10	Round Pin	J1-J16	16P	1	
11	Infrared sensor	JS	VS1838B	1	
12	Self-locking switch	S		1	
13	Button	S1		1	
14	Male Pin	X	4P	1	
15	3mm LED		Colorful	271	
16	USB/Audio Cable		45mm	1	
17	Copper pillars		M3*10	4	
18	Screw		M3*6	4	
19	USB-TTL Downloader			1	
20	DuPont line		20mm	5	
21	Remote control			1	include CR2025 battery
22	Cable		4.2m	1	
23	PCB		78*78	1	
24	Acrylic welding template		90*90mm	1	

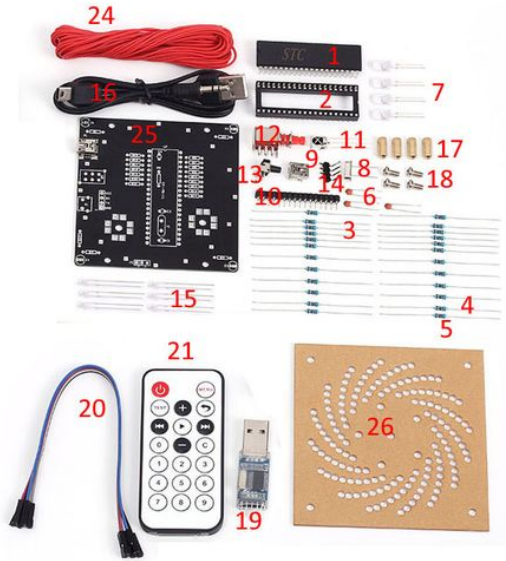

## Step 4: Infrared Remote Control Description

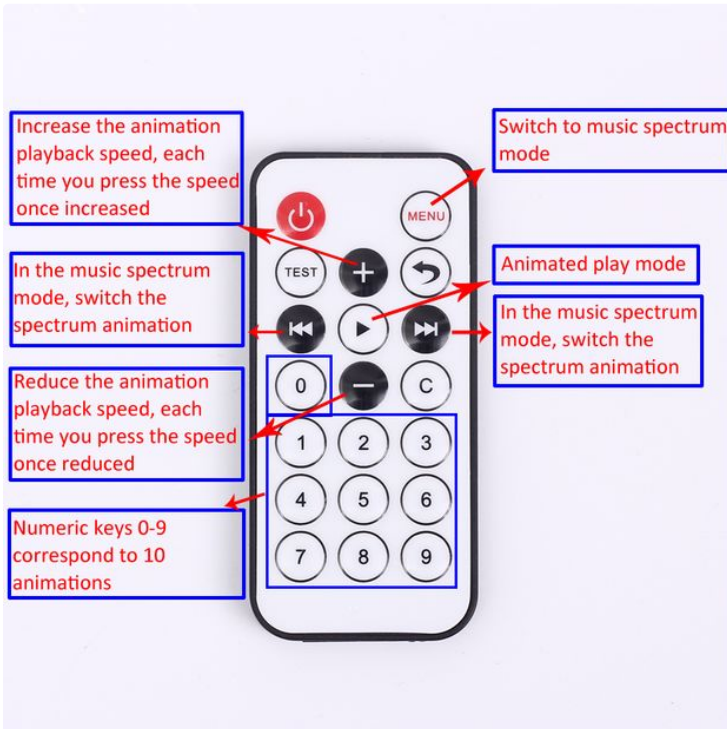

## Step 5: Installation Steps-Install Circuit Board

### 1>.Tips before installation:

- 1).Check that all of the LED can be illuminated;
- 2).Note the direction of each component;
- 3)The following is a detailed description of the installation. There are other installation methods in the end of the document;

### 2>.Install Circuit board(SMD MINI USB may have been installed):

- 1).Step 1:Install 10K,100K resistor,3pcs 30pF capacitor.
- 2).Step 2:Install Crystal and 20pcs 300ohm resistor

3).Step 3:Install DIP-40 IC socket.

4).Step 4: Install Self-locking switch,Button,VS1838B Infrared sensor and 4P male pin(Recommended use and do not use round female pin as shown)

5).Step 5:Install 4pcs 5mm colorful LED and note direction

6).Step 6:Install 16pcs Round Female pin on other side of PCB on J1-J16 pad.It is use for LED

7).Step 7:Install and test.Connect power by MINI USB,Colorful LED will flash.Otherwise:  
A. Check for the presence of Weld B. Check if there are components installed incorrectly

Step 1

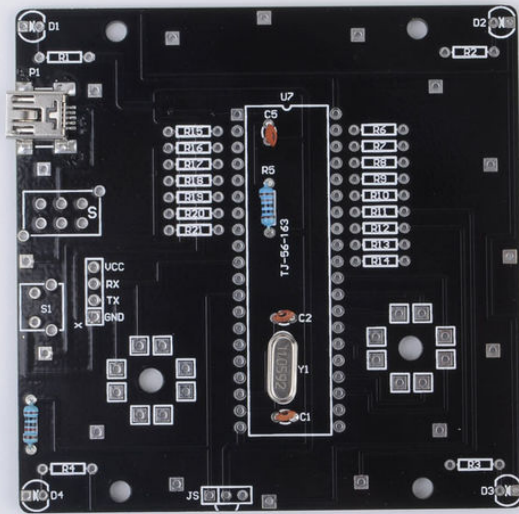

Step 2

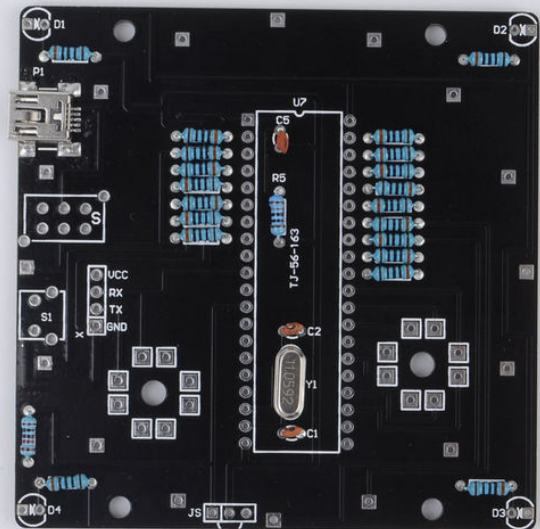



Step 3 pay attention to the installation direction

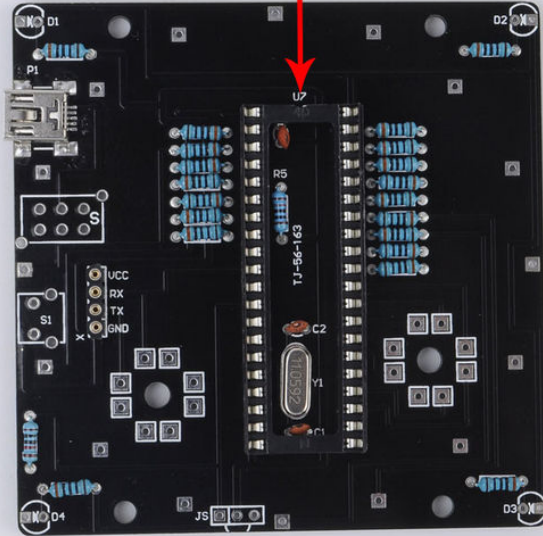

Step 4 Recommended use and do not use round female pin

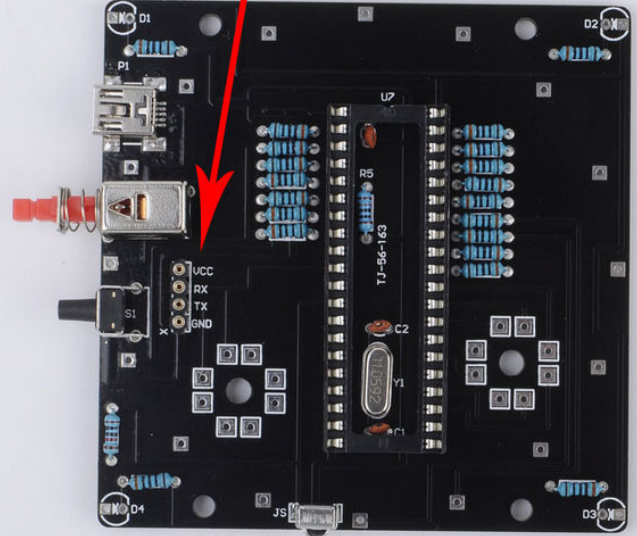

Step 5

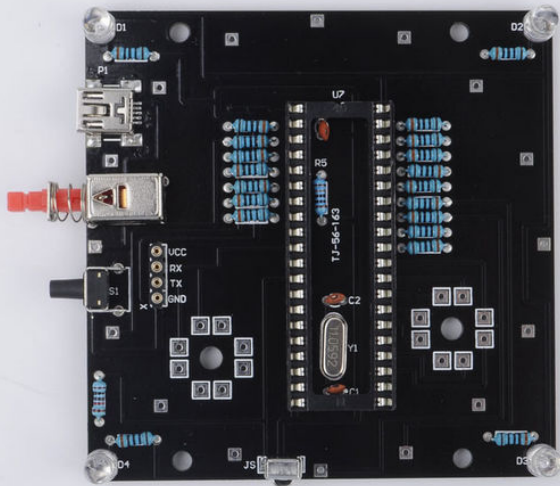

Step 7 Pay attention to the installation direction

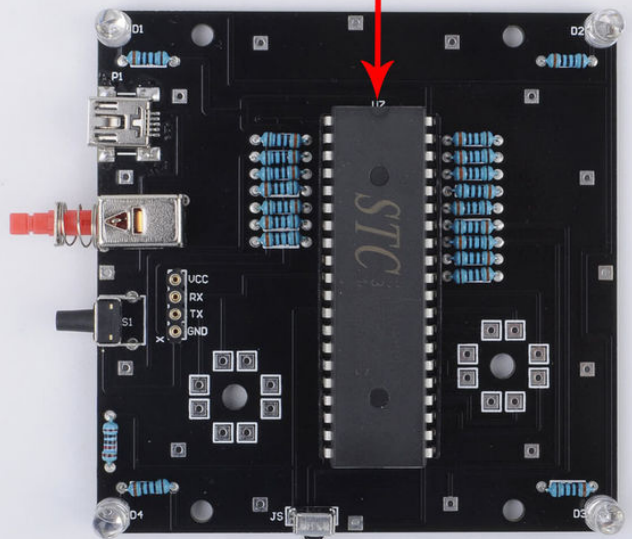

## Step 6: Installation Steps-Install LED of Tower Main Body

1).Step 8:Install 4pcs Copper pillars and M3 Screw on Acrylic welding template.According to the rules shown,the outermost is the first ring:1st Ring

2).Step 9:Process LED.Curved LED's longer pin(Positive pole) and form a right angle.Please be careful not to damage the LED.

3).Step 10:Make the 1st layer LED of Tower main body.Put the already processed LED on 1st Ring.Short pin(Negative pole) outward,Longer pin(Positive pole) interconnection.

4).Step 11:Make the 2nd layer LED of Tower main body.Choose the 2nd Ring on Acrylic welding template as shown.The make method is the same as the 1st layer.

5).Step 12:Make the 3rd layer LED of Tower main body.Choose the 3rd Ring on Acrylic welding template.

6).Step 13:Make the 4th layer LED of Tower main body.Choose the 4th Ring on Acrylic welding template.

7).Step 14:Make the 5th layer LED of Tower main body.Choose the 5th Ring on Acrylic welding template.

8).Step 15:Make the 6th layer LED of Tower main body.Choose the 6th Ring on Acrylic welding template.

9).Step 16:Make the 7th layer LED of Tower main body.Choose the 7th Ring on Acrylic welding template.

10).Step 17:Make the 8th layer LED of Tower main body.Choose the 8th Ring on Acrylic welding template.

11).Step 18:Make the 9th layer LED of Tower main body.Choose the 9th Ring on Acrylic welding template.

12).Step 19:Make the 10th layer LED of Tower main body.Choose the 9th Ring on Acrylic welding template.

13).Step 20:Make the 11th layer LED of Tower main body.Choose the 9th Ring on Acrylic welding template.

14).Step 21:Make the 12th layer LED of Tower main body.Choose the 8th Ring on Acrylic welding template.

15).Step 22:Make the 13th layer LED of Tower main body.Choose the 7th Ring on Acrylic welding template.

16).Step 23:Make the 14th layer LED of Tower main body.Choose the 6th Ring on Acrylic welding template.

17).Step 24:Make the 15th layer LED of Tower main body.Choose the 5th Ring on Acrylic welding template.

18).Step 25:Make the 16th layer LED of Tower main body.Choose the 4th Ring on Acrylic welding template.

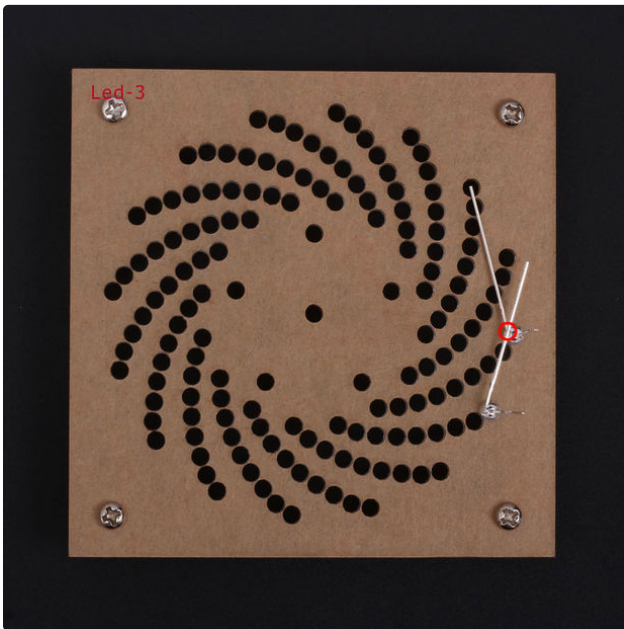
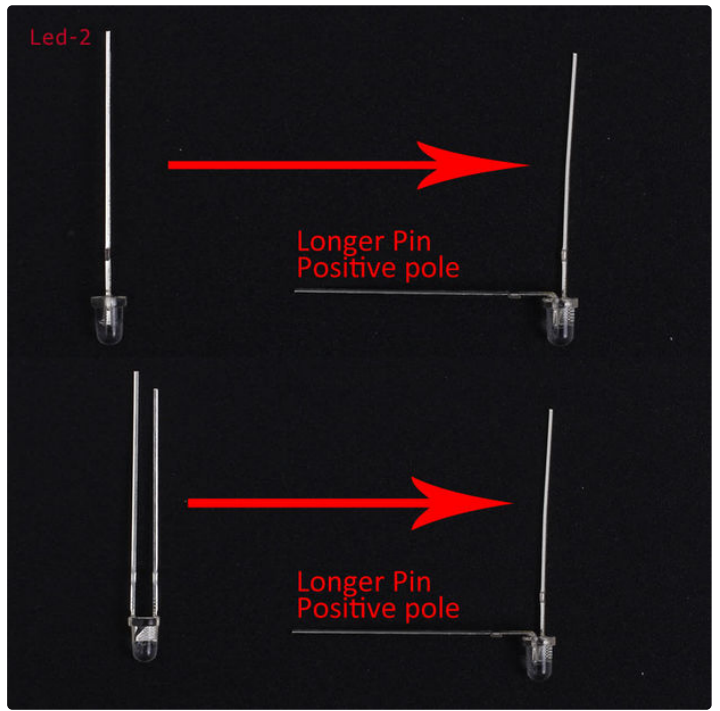
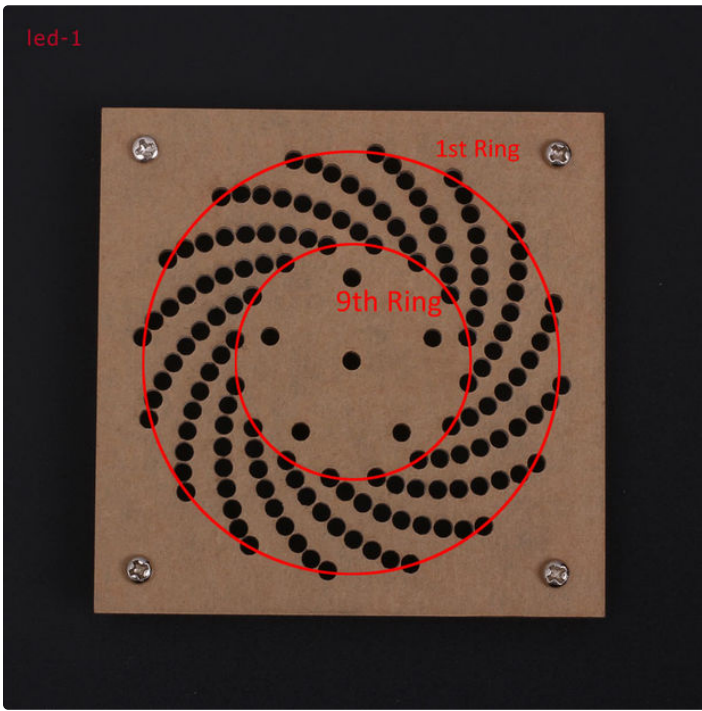



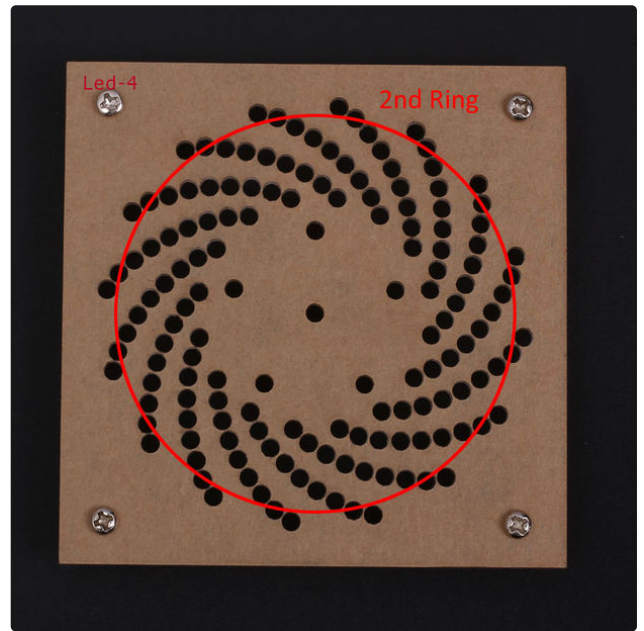

## Step 7: Installation Steps-Install LED of Spire

There four layers for spire. The distribution of LED is 5-3-3-1. That is the 1st layer is 5pcs LEDs, the 2nd and 3rd layer is 3pcs LEDs, the 4th layer is 1pcs LED.

1). Step 26: Make the 1st layer LED of spire. Choose the 10th Ring on Acrylic welding template. The make method is the same as the 1st layer of Tower main body.

2). Step 27: Make the 2nd layer LED of spire. Choose

the 11th Ring on Acrylic welding template.

3). Step 28: Make the 3rd layer LED of spire. Choose the 11th Ring on Acrylic welding template.

4). Step 29: The 4th layer LED just consist of 1pcs LED. Well, so far, each layer of LED are made well, and now need to connect layer and layer together.

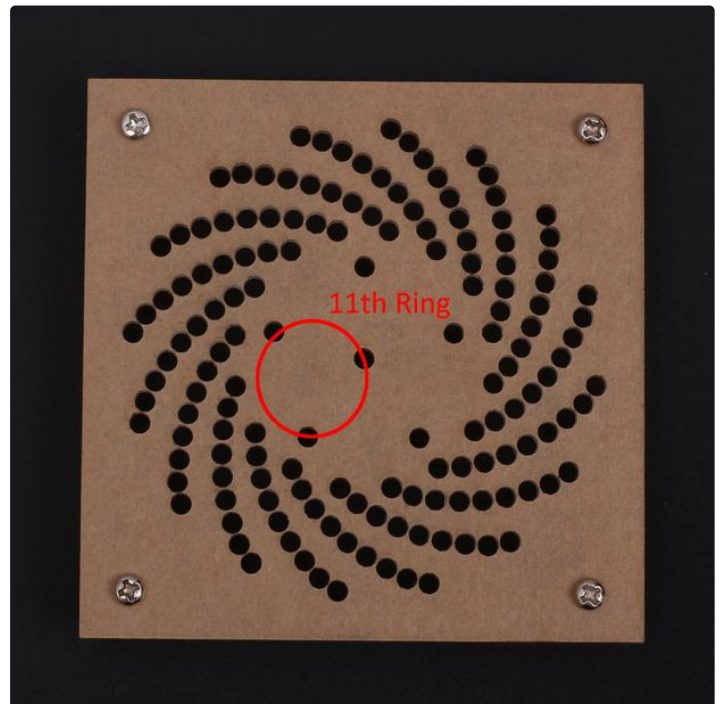
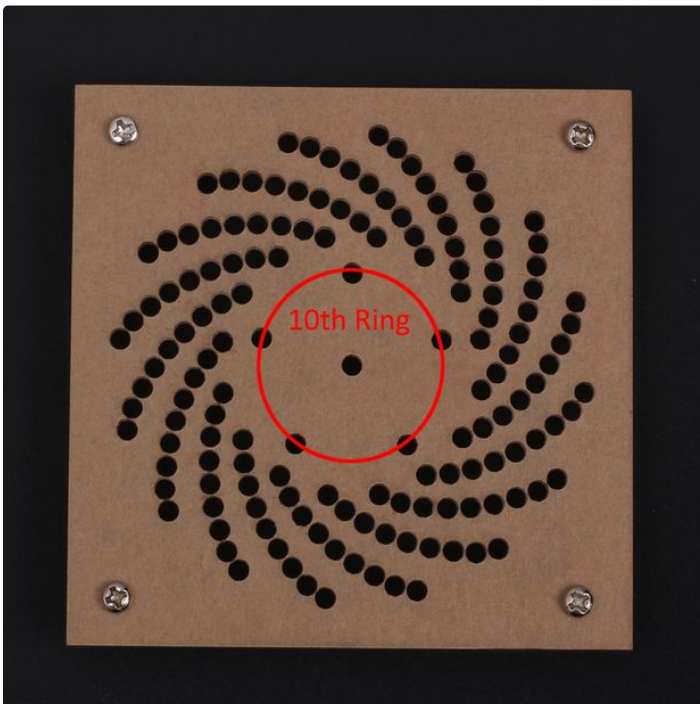

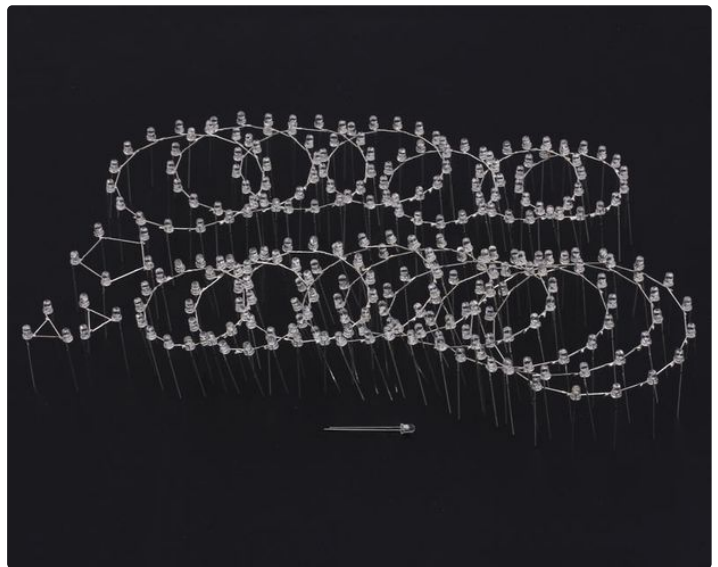
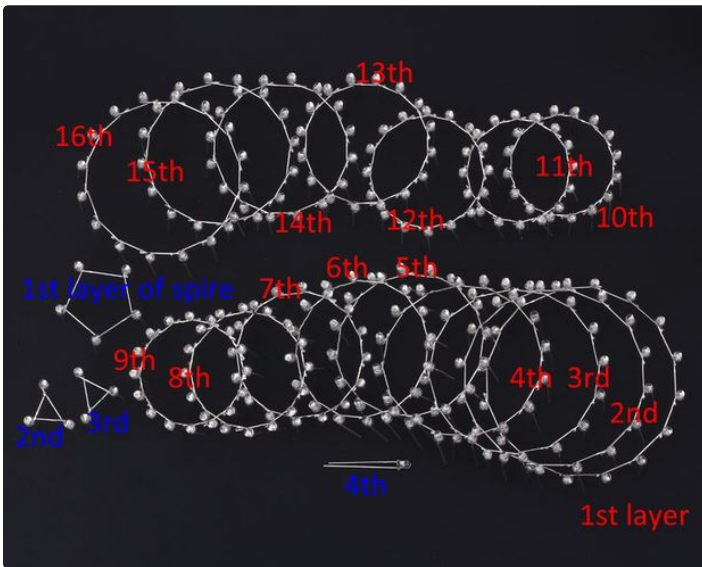

## Step 8: Installation Steps-Connect Layer Each Other

Step 30: Bend the LED pins slightly as shown the pins are bent upwards and inward. The purpose of the bend is to connect the next layer of LEDs.

**NOTE:** The 1st layer have no need to bend pins. It can insert into female round pin or welding on J1-J16 directly.

Step 31: Put some tin on the root of negative pole in order to fix next layer LED.

Step 32: Install the 1st layer on PCB. NOTE: It is install on the other side!!!

Step 33: Weld bend pin from the 2nd layer on tin on the root of negative pole. But also to ensure that the current layer and the next layer a little bit of dislocation

Step 34: Install the 3rd ~ 16th layer as the same method.

Step 35: Install spire. There are 16pcs LED on the 16th layer of Tower main body and 5pcs LED on the 1st layer of spire. So there are 3pcs LED on the 16th layer between 2pcs LED on the 1st layer of spire, and others just have 2pcs LED. Please see picture, you can understand clearly.

Step 36: Install the 2nd layer and the 3rd layer of spire.

Step 37: Install the 4th layer of spire. Negative pole connect to the negative of the 3rd layer and positive pole connect to the positive of the 3rd layer of spire.



Step 32

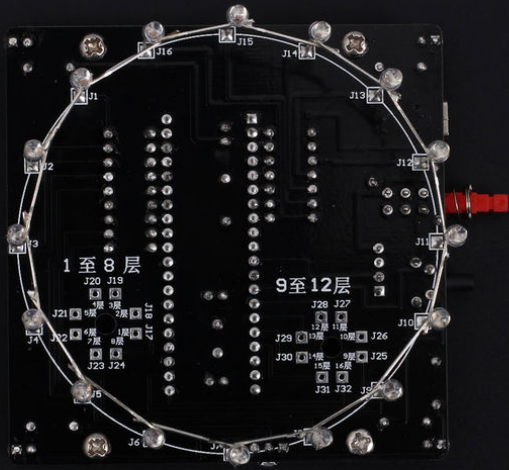

Step 32-1

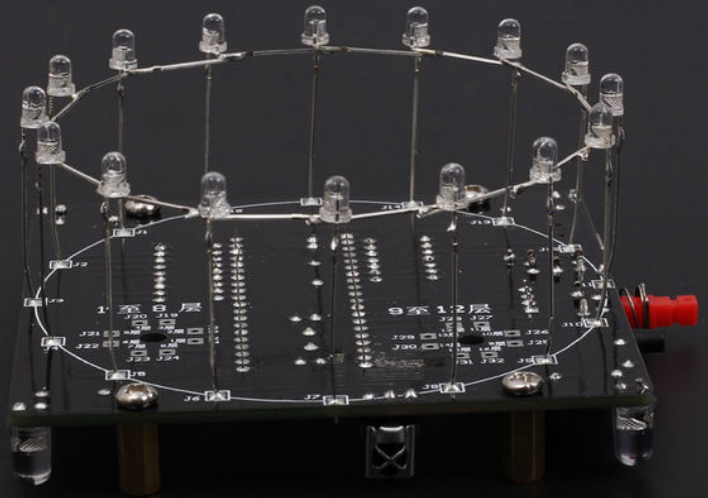

Step 33

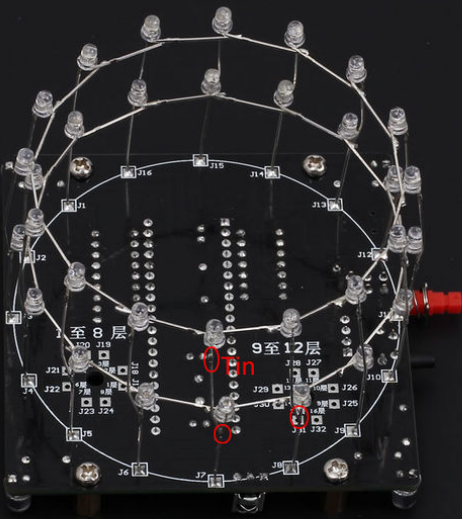

Step 34

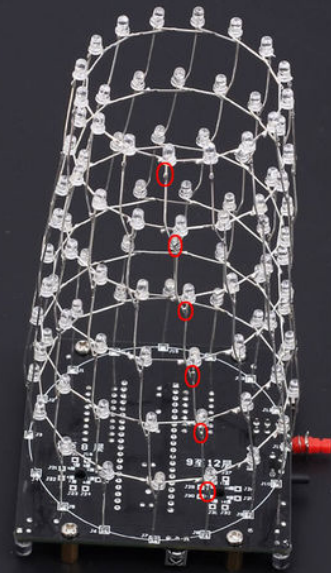

Step 34-1



Step 35





## Step 9: Installation Steps-Connect Layer Each Other

Step 38: Connect all positive pole the four layer of spire together by jumper and then connect it to the 16th layer of Tower main body.

Step 39: Connect each layer of Tower main body to J17-J32.

The 1st layer connect to J17 by wire;

The 2nd layer connect to J18 by wire;

The 3rd layer connect to J19 by wire;

The 4th layer connect to J20 by wire;

.....

The 15th layer connect to J31 by wire;

The 16th layer connect to J32 by wire;

Step 40: Connect other layers.

Step 41: Install IC and Connect power to test! So far, finished. To check own results.

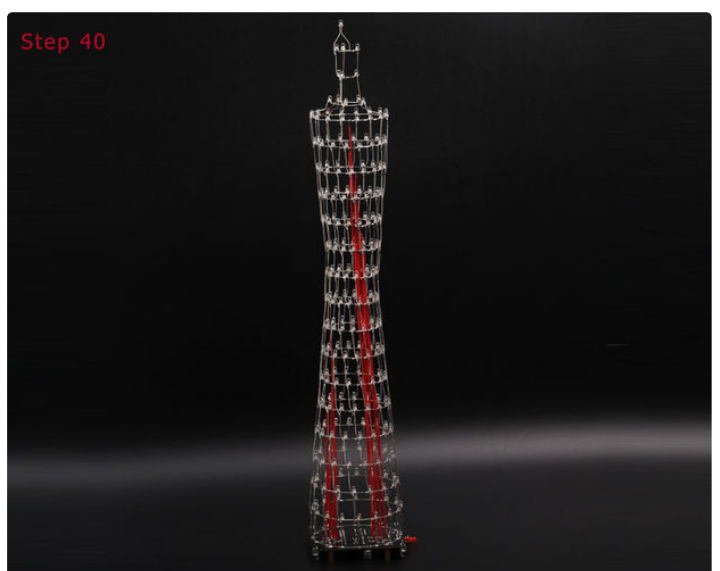
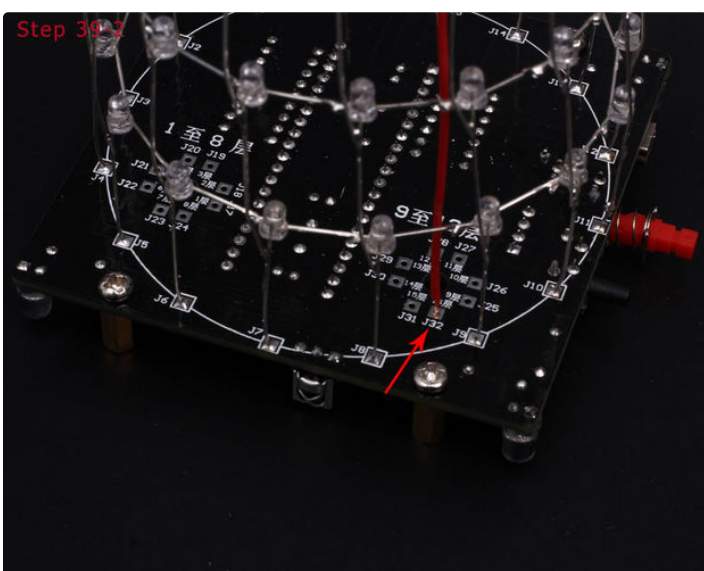
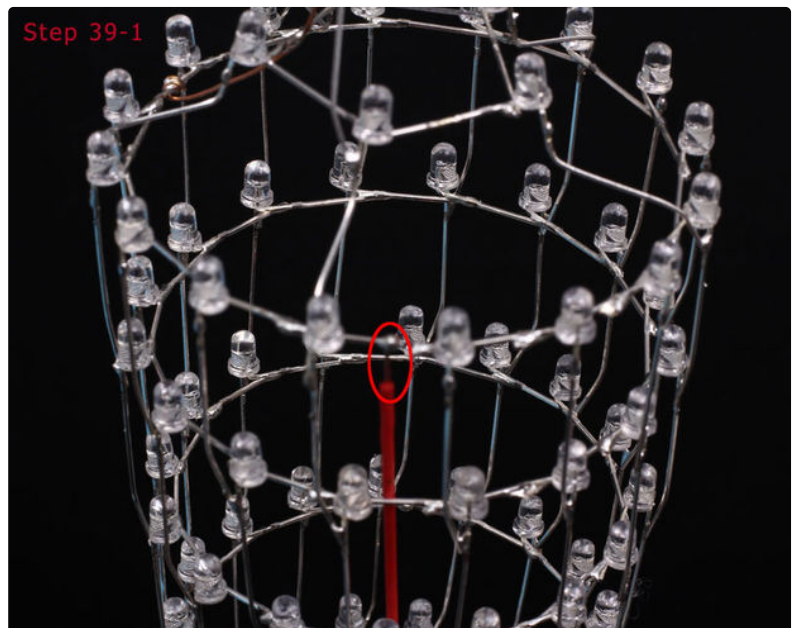
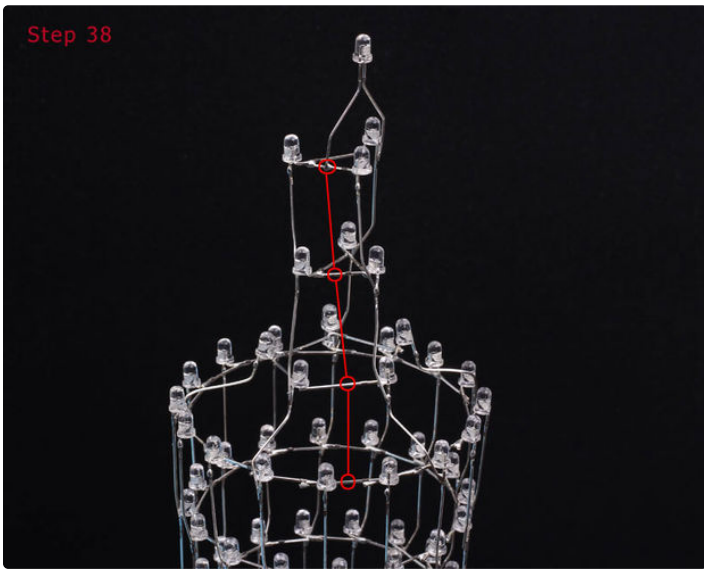



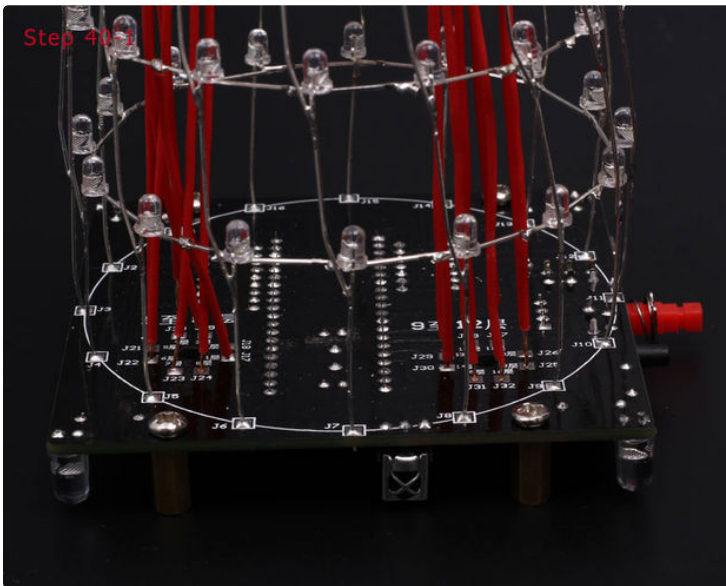

## Step 10: Installation Finished and Effect Demonstration

Finally you get a completed Tower Kit with colorful led display. Populay application for 1>.Home Furnishing decoration 2>.Store decoration 3>.Graduation design 4>.Practice for electronic enthusiasts 5>.Holiday gifts

If you want to have a try, click here to get this Tower Display Rhythm Lamp Light with Infrared Remote Control from us ^0^

